

Smart Car

Mr.Fenil Gangar¹, Miss. Jinal Shah², Prof. Era Johri³

Student, Bachelor of Engineering, Department of Information Technology, K J Somaiya College of Engineering,
Mumbai, India^{1,2}

Assistant Professor, Department of Information Technology, K J Somaiya College of Engineering, Mumbai, India³

Abstract: Automobile technology when integrated with robust advanced computer technology can help to create powerful smart car, things can change drastically to ease user drive and avoid accidents. The approach mentioned in this paper will diminish accidents by predicting human psychology and behaviour to a certain extent. Driving a car that can understand you, your feelings and your expressions while driving indeed help to prevent accidents. Long distance journey alone can fluctuate your mood many times due to many reasons. In such cases an understanding intelligent music player in car and mobile friendly app assistance can help a person to be secure during his drive. If the driver is stressed or angry then it can be dangerous to continue further drive which might result in fatal accidents. Sometimes if person is not paying attention on road or he is driving his car rashly, our system will take care of all those things and comfort the driver with all safety measurements and entertainment techniques to reach his destination safely.

Keywords: Avoid Accidents, Driver assistance, Electronic Stability Control (ESC), Autonomous Braking System (ABS), Car Security Application, Collision Detection, Alcohol Detection, Deactivation of ignition, Intelligent Music player.

I. INTRODUCTION

In today's fast paced world with the tremendous advancement in technology, cars are getting more and more intelligent day by day with self-learning and evolving technology integrated in them. Today they are evolving in such a highly advanced state that they have begin to analyse the surrounding situation autonomously and to take accurate decision by their own with the help of integrated artificial intelligence placed in them by their developers which have resulted that cars today are able to react on their own, but the real matter manning the helm is still the car's Achilles heel.^[4] To solve such one to the biggest challenges facing such technology we are associating this technology with Big Data which has potential to handle enormous amount of data using powerful techniques and to predict human behaviour. Big Data today is no longer just the domain of IT field, but has spread to touch many crucial areas from marketing to different enormous operations in field of advanced Security and technology. However bigger Data isn't necessarily better. The big data we have is only valuable, if it process correct information. Integrity of present data in database plays a vital role in Big data technologies, if used correctly. Using Big data with our system we can really built a powerful, secured and robust application with a real competitive advantage. In this technology, we will have a camera installed on the dash board of the car which is going to continuously capture images of the driver's facial expressions to determine the mood of the driver and will also track eye movements of driver. Powerful facial expression recognition camera will analyse the mood of the driver based on his facial expression captured by camera while he is driving his car and will produce flag warnings if necessary. If the car facial recognition system installed in car detects that driver is not in a normal mood then it will take necessary precautionary measures to

change the mood of the driver by intelligently playing music according to the current mood of driver. The intelligent integrated Music Player in our system will play the music according to various moods just to make the driver relaxed and prevent collisions. We have also integrated collision detection and avoidance system which will help in speed cutting if collision is detected, combined with Electronic Stability Control (ESC) technology and Autonomous Braking System (ABS) in our system for advanced safety measures. One Main motto of our system is to provide safe and secured journey to driver.

II. THEORY

In this paper we propose an application where we will integrate four systems together to compute a driver feasibility to drive a car safely. We design this app to integrate and make a fully automated app which will recognize facial expressions of a user and accordingly we will automate the process so that a user can drive safe. We will fetch the outcome of the facial recognizer and input it to music player system. To avoid untoward circumstances we integrate this application to automatic notification system to inform about details of the user to his relatives by sending them the exact location of the driver using GPS.

A. FACIAL EXPRESSION RECOGNITION WORKING
Since there are billions of cars and drivers across the globe and each driver of the car has different moods at different times depending on the current situation of driver, we can say that there will be a wide range of facial expressions for different people. In order to analyze this massive amount of data containing collection of stored facial expression of each driver we approximately need a database of over a billion of facial expressions which is only possible with

the use of the Big Data, in order to get proper analysis done on each stored facial expression of a person and the retrieval of accurate data when required. The results will be generated by facial recognition system to accurately recognize and match the correct facial expression with preferred emotion from over the huge database and predict and classify preferred human primary emotions or moods such as happy, depressed, anger etc with over 90% of accuracy given by using this facial expression algorithm used.

The System is so intelligent that facial expression recognizer camera integrated in car is also able to intelligently identify fake moods by distinguishing between the actual variations of mood and pretended emotions shown purposely to the camera by driver. So to naturally get what's going on inside a driver's mind state, we have started going through their faces, studying their expression in different situations and environments and analyzing their facial expressions and changes in movements of their muscles present over the face of a driver in order to predict whether the driver at the wheel is too depressed, too sleepy or even in a too angry or exhausted state to safely control their ride and to reach their destination safely.

The facial expression recognition system that uses a camera to capture facial expressions of a driver and software to detects for unusual activities like fake facial expressions or masks being put on. Integrating this technology in the car presents a different set of challenges, firstly starting from where to fit the camera like on the dashboard so that it doesn't obstruct the driver's view while he is driving. Another hurdle is acclimatize to the repeated changes in lighting conditions inside the car, such as when driver is driving during a late night or even during very early morning or if a car goes into a tunnel where there will be complete blackout and camera won't be able to capture the facial expressions of the driver, to overcome this hurdle the facial recognition camera is integrated with infrared rays which allows the camera to capture the facial expression during low-light conditions in order to increase the reliability of the system.^[1]

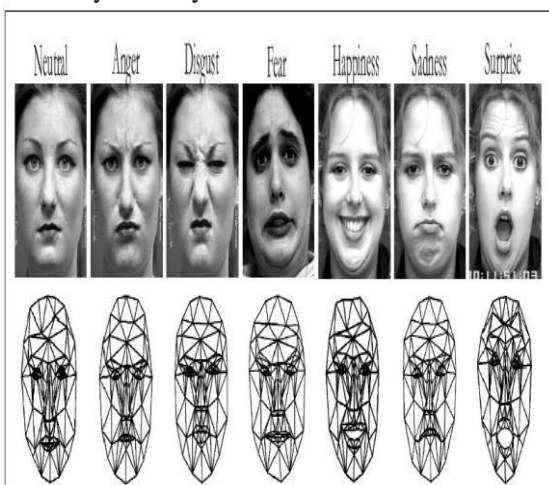

Figure 1-Different moods of Humans.

In today's world, there are different ranges of very popular facial expression recognition algorithms found and used which are based on concept of Principal Component Analysis (PCA) using Eigen faces, Linear Discriminate Analysis (LDA) and laplacian face expression algorithm. Using these algorithm main motives is to identify a number of notable features of the face. All the features appended together to form nearly 80 nodal points. The algorithm used for facial expression recognition system identifies and differentiate the face from its framework by some of the habitual nodal points given below.

- Interspaces across the eyes.
- Distance downwards of the eye sockets
- Stretch of jaw-line
- Nose span
- Cheekbone appearance

The above nodal points are calculated altogether to furnish a common numerical code known as the face print.

III. 3-D FACIAL RECOGNITION TECHNOLOGY

The above described hurdles were all fixed with the advancement of 3-D Facial expression Recognition Technology. As 3-D replica of a driver's face helps to mark out clearly the non-identical nodal points, this practice happened to be more precise. All the depression and bulge of the face are further noticeable and this assist a lot in collate with the data present in huge database. The 3-D mechanism also discards the drawback of meticulous lighting strand. Thus, the image of the driver can be captured even in unsuitable lighting conditions and also in any projection [in an extent of practically to 90 degree]. Given down are the unique points that occur when the individuality of a driver is confirmed with an existing data from huge database.^[3]

1. Calibration of picture

For a 2-D image, the system can be exact only if the angular location of the face with respect to camera is not less than 45 degrees. But for a 3-D replica, the system can be more detailed even if the angular spot of the face with respect to camera is at 90 degree. The proportion and pose can also influence the perfection.

2. Computation of face print:

The face expression recognition software makes arrangements on the divergent curves present on the face. The face will be measured in form of micrometer ratio.

3. Convey of Calculations

The calculations made are taken and then converted into a distinctive code. This code makes each arrangement distinct and thus demonstrates the unique characteristics of the face.

4. Symmetry of faces

The similarity can be categorized into two parts according to its motive. First one is verification and the other one is recognition. If a driver is to be identified as one who

claims to be an owner of a particular car, it is called verification. This type of correlation will with the database will occur in a 1:1 ratio. For the recognition of a thief, the picture received will be equated to all the pictures in the database in a 1: N ratio. The comparison practice is performed in three different methods.

They are as follows-

1. Vector arrangement- This arrangement is used for rapid search within the database in pair the 1:1 and 1: N ratio.
2. Local Feature Analysis [LFA] – This arrangement largely pursue the vector arrangement. This type of search is a little more complicated.
3. Surface Texture Analysis [STA] – This is the most complicated search technique of all the three mentioned. It comes behind the LFA and the search is performed on the skin features of the picture, which contains the most circumstantial information.

When these arrangements are incorporated in the facial expression recognition software, the system is able to recognize and verify the person even if there are changes in his expressions like smiling, depressed or in anger state. Even a growth in beard or moustache will not influence the correctness of the system software.

Today, facial expression analysis and emotion prediction has become an effective research area topic that finds capability in practices in such an areas where frequent appealing human-computer coalesce, talking minds ,image regeneration and person’s emotion scrutiny.

General facial expression analysis structure- The circle numbers are used in the system illustration presented further downwards and designate pertinent handling phase. The facial distribution, the facial bisection and facial attribute description phase are only needed in synchronicity with some particular facial characteristic withdrawal and stratification practices.

Nowadays, many of the facial expression analysis technologies strive to plot facial expressions instantly into basic emotional classification and are thus unqualified to manage facial activity produced by a non emotional mental and bodily movements. A resolution to this dilemma, as it permits to categorize facial expression preliminary to any clarification venture.

Maximum performance has to be acquired in the sector of Advanced facial expression definition with view of concatenation of alternative communication passage such as voice recognition and gestures recognition.

However facial expressions frequently arise throughout discussion. If these facial expression analysis technologies are to be functioned by self ruling, on-going characteristics extraction techniques have to be enhanced and expanded with a view provide to prosperous in real environments as well as autonomy of manual involvement during input and at delivery.^[7]

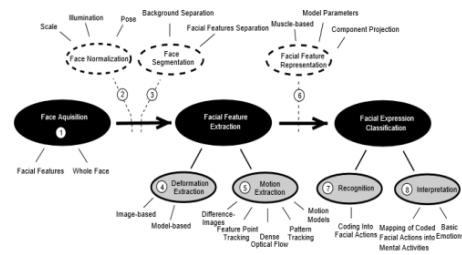

Facial expression analysis system is an intrinsically multifaceted held and it is essential to observe at it from all the different fields elaborated in succession to acquire perception on how to construct well founded facial expression analysis systems. Nonetheless, majority of facial expression analysis systems have seeked to plot facial expressions straightly in direction to basic emotions, which demonstrate an ill-posed complication. Facial expressions are produced by diminution of facial muscles, which effects in materialistic disfigure of facial characteristics like as changes in eye lids, eye brows, nose, lips frequently disclosed by crumple and bulges on the face . Classical modification of muscular actions are short , enduring up to few seconds, but hardly more than 3 s or less than 200 ms. We would like to flawlessly calculate facial expressions and analyze them and accordingly need a functional nomenclature for their representation .And of significance is the plotting of facial expressions , their potency as well as their productivity .

IV. MAINTAINING THE INTEGRITY WITH MUSIC PLAYER

Depending on the outcome by facial recognition system we will take precautionary measures. If the state of mind is cool and normal of the driver, the integrated intelligent music player would play songs without any conditions. But if the state of mind and expressions on face are uncommon like depressed, sad or in anger then the music player will take a notice of it and play the music tracks depending upon the current emotion which is predicted based on past history database of the driver. The database will consists of the playlists which were played by the driver in past when the emotion was similar .As a result of which the driver’s mind would be deflect to listen to pleasant music which may improve his mind state and reduce the risk of accidents which will act as safety precaution for being vulnerable to accidents to some extent. By keeping a track on the driver’s eye moments, system can also detect whether driver is feeling drowsy. In such scenarios the system will alert the driver by putting ON the alarm with loud volume.

The system is programmed in such a way that when it recognizes that the driver is exhibiting anger or shows some kind of stress then, the Music player would not take automatic actions to frustrate the driver. Rather the system will send message notifying the relatives or family members of driver about such act. Only information of behavioral aspect would not make any sense for the rescuer of driver. The system will also notify the current location of driver to the relatives showing the

measurement of distance that would estimate how much long time it would take to arrive for the driver to reach its desired destination safely. This location scan is done by the GPS integrated in the car, in order to trail driver's location we are using a GPS tracking unit. Which is a small device, normally fetched by a moving car, that uses the Global Positioning System to direct and locate its precise location and hence that of its carrier, at given intervals of time Recorded location of car can be stored inside the app so that it may be conveyed to a family members using notification message. This permit's the car's location to be present against a map backdrop in real time to the family members of the driver. Thus the rescuer would be aware of the location and can communicate with the driver accordingly.

The data of the relatives like phone number would be stored in compressed and encrypted formats in the database. As there are billions of cars and millions of drivers, it would at least reserve ten data records of relatives per driver. The data is stored according to the priority of the driver. So that system can notify or inform the rescuer about the Driver's location and his destination location. There may also be a case that the rescuer who is at top priority did not respond to the apps notification message; under such crucial circumstances acknowledgements will play the vital role. The app is programmed in such a way that in such case it would notify the next person from the database and this loop will continue until an acknowledgement is received from at least one relative.

During this process is ongoing different thoughts come and go from the driver's mind. So, the system should also take care that the speed of vehicle is under control. This is to prevent intentionally racing the car, rash driving, jumping the signals; the GPS and the speedometer are integrated for such environment.

V. COLLISION DETECTION TECHNOLOGY

Yet self-driving cars which as normally termed as autonomous car are still some years away, but few of their superior characteristics are already accessible on some of the cars and this technology can rescue the driver from an accident. A collision avoidance & detection system is a safety system formulated to avoid or reduce the severity of an accident of car. It is also termed as forward collision warning system or collision mitigating system(CMS), it uses radar mechanisms and laser technology along with infrared camera fitted front in and back body of car to continuously monitor incoming obstacle and in order to detect an forthcoming crash.^{[10],[8]}

This technology incorporated in your car system can glimpse site of other vehicles or incoming obstacle well in advance before they reach in your line of sight, forecast some category of crash Once the obstacle is identified and its detection is done, these technology will either furnish a warning notification to the driver in order to take appropriate action to avoid accident but when the driver is

not in position to respond to the given warning by the car , then car will autonomously take decision by cutting the its speed in order to protect driver of car Collision avoidance by braking is suitable for vehicle at low speed (e.g. below 60 km/h), while collision avoidance by controlling steering is suitable for vehicle at higher speeds.[6]

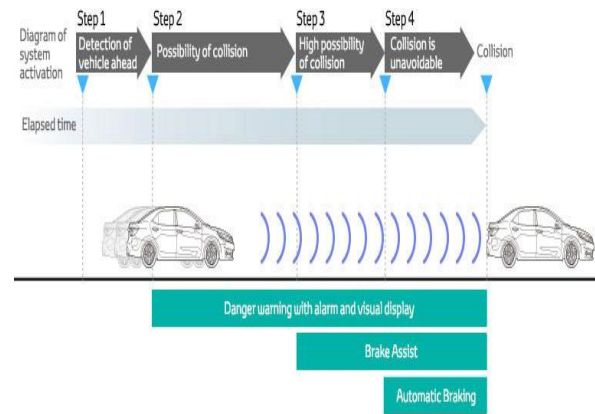

ELECTRONIC STABILITY CONTROL (ESC)-

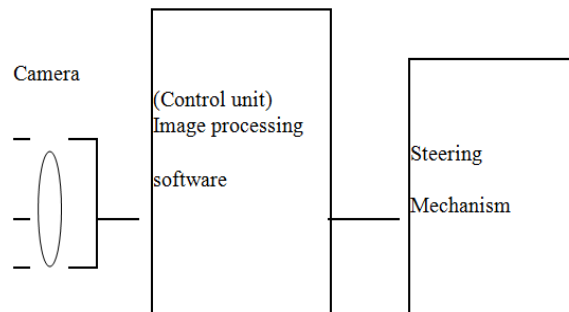

Along with collision detection system this technology also combines Electronic stability control (ESC), also referred to as electronic stability program it is a computerized technology that enhances car's stability on road by diagnosing and diminishing loss of grip of tyre. When it identifies drop in steering control, it accordingly puts on the brakes to help control the movement of car where the driver aims to go ahead .The system also minimize the engine power of car until proper control is retained by the car .This technology not only improve a car's performance but, it also helps to minimize the loss of control.

Many a times it happens that driver is not paying attention on road while driving ,this may happens mostly when driver is on call while driving his car , in some cases it may happen that driver by mistake drives the car in opposite lane ,this could lead to serious and big collision if any other vehicle is coming from opposite direction .

In order to prevent this things from happening system is also programmed to indicate and warn the driver that he is driving in a wrong lane until the indication of changing the direction is given by driver .This technology incorporated in cars may help in prevention of accidents.

VI. ALCOHOL DETECTION AND DEACTIVATION OF IGNITION

Now days, many accidents are occurring because of the alcohol consumption by the driver. Thus drunk driving is a prime cause of accidents in nearly all countries across the globe. To solve this problem we have integrated Alcohol Detector system in car, which is placed for the safety of the driver seated inside the car. The prime component of this technology is an Alcohol sensor. If the driver inside car has consumed alcohol then it is detected by the sensors which are placed around the steering wheel. This advanced Sensors gives indication to a comparator IC connected to the engine of car, due to which the ignition of the car engine is deactivated and user is unable to start his car as result of which he is denied from driving his car because he has consumed alcohol. So this will protect the driver from being a victim of Drunk and drive case also .With the help of incorporated GSM technology in the system, the car will also send message in order to inform the relatives or family members of the driver that he has consumed alcohol and he has denied from driving his car so accordingly family members can communicate with the driver.^[9]

VII. CONCLUSION

With the concoction of different systems together on one platform like facial recognition system, music player integrated to the mood of a person, alcohol detection system and collision detection system, we can maximize driver's safety while driving. With real time analysis of parameters like mood fluctuations, auditory alerts to driver and notifying the relatives automatically in case of emergency are some of the highlighted features of our system. Along with it analysis of drivers behaviour and habits is taken care of which will help driver to avoid potential risks for them and for neighbours. Our mood detection system along with mood relaxing using music player paves way for more innovative applications. Unlocking the potential of our Intelligent Car System not only logically but practically too, this maximizes the possibility of driver and the neighbours being safe on road.

REFERENCES

- [1]. S. Koelstra, M. Pantic and I.Patras, "A Dynamic Texture based Approach to Recognition of Facial Actions and their Temporal Models", IEEE Trans. Pattern Analysis and Machine Intelligence (Accepted). bibtex
- [2]. en.wikipedia.org
- [3]. Luettin, J.: Automatic Facial Expression Analysis: A Survey. Pattern Recognition 36(1), 259-275
- [4]. <http://www.wired.com/>
- [5]. <http://www.circuitstoday.com/>
- [6]. http://www.toyota-global.com/innovation/safety_technology/safety_technology/pre-collision_safety/
- [7]. Keltner, D., and Ekman, P.: 'Facial expression of emotion', in Lewis, M., and Haviland, J.M. (Eds.): 'Handbook of emotions' (Guilford, 2000, 2nd edition), pp. 236-249.
- [8]. <https://www.stopdwi.com/>
- [9]. Peden M, ScurfieldR, Sleet D, et al, eds. "World report on road traffic injury prevention". Geneva: World Health Organization, 2004.
- [10]. Kiefer et al. "Forward Collision Warning Requirements Project Final Report", NHTSA DOT HS 809 574, 2003.